

# KUZCO LIGHTING

103-19099 25th Avenue  
Surrey, BC, Canada  
V3S 3V2

T: 604-538-7162  
T: 1-855-85-KUZCO  
F: 604-538-7196  
W: kuzcolighting.ca

## PRODUCT SPECIFICATIONS

### MODEL NO.: 81612

**MODEL NO:** 81612

**DESCRIPTION:**

Two lamp fixed track, with brushed nickel finishing.

**LAMPING:** 2 X 50W GU10

**VOLTAGE:** 120V

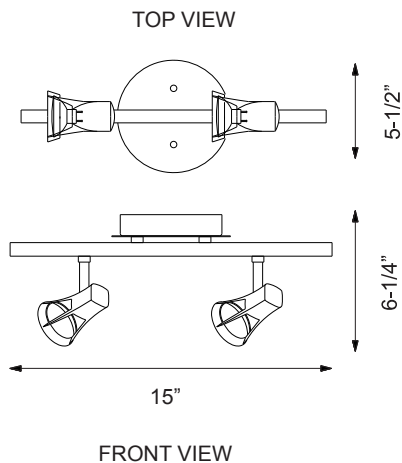

2010 Kuzco Lighting, All Rights Reserved.  
Kuzco Lighting reserves the right to change specifications  
for product improvements without notification.  
This item is approved by ETL.