

Installation Instructions

For Sconce 20-6410 & 20-6410F

B211

Page 1 of 2

CAUTION: FAILURE TO INSTALL THIS FIXTURE PROPERLY MAY RESULT IN SERIOUS PERSONAL INJURY OR DEATH AND PROPERTY DAMAGE. We recommend installation by a licensed electrician.

This product must be installed in accordance with applicable installation code(s), by a person familiar with the construction and operation of the product and the hazards involved.*

Caution: Do not exceed maximum wattage noted on fixture. Use only recommended bulbs with fixture.

Please Note: This fixture is designed to be mounted on a standard wall surface and may not be suitable for all applications. If installing in a non-wood frame application, we recommend consulting a qualified builder or electrician.

To Mount Fixture to Wall (Figure 1)

Component Parts

- A Crossbar
- B Threaded Stud (2)
- C Knurl Ball (2)
- D Fixture Assembly
- E Ground Screw

Caution: Be sure power is off at the main breaker box prior to installation.

1. Carefully unpack the fixture from the carton.
2. Using two machine screws (not provided), fasten the crossbar (A) to the electric box making sure that fixture mounting holes are level.

Note: A new electric box comes with screws. When replacing a fixture, retain the existing screws for use with the new fixture.

3. Thread studs (B) into the appropriate holes in the crossbar (A). Adjust the studs to proper length to ensure the fixture will fit snugly to the wall.
4. Hold the fixture assembly (D) close to the wall and using suitable wire connectors, not provided, connect fixture wires to supply (white to white or ribbed and black to black or smooth). Run a pigtail lead from crossbar ground screw (E) to the junction box and connect all ground wires (bare copper or green to bare copper or green).
Caution: Make sure wire connectors are twisted on securely, and no bare wire is exposed.
5. Slide fixture assembly (D) over threaded studs (B) and push firmly to wall, making sure that no wires are pinched between fixture back and wall. Fasten with knurl balls (C). Be sure threaded studs (B) are fully seated in the knurl balls (C).
6. See instructions on next page to install glass or shade depending on option purchased.

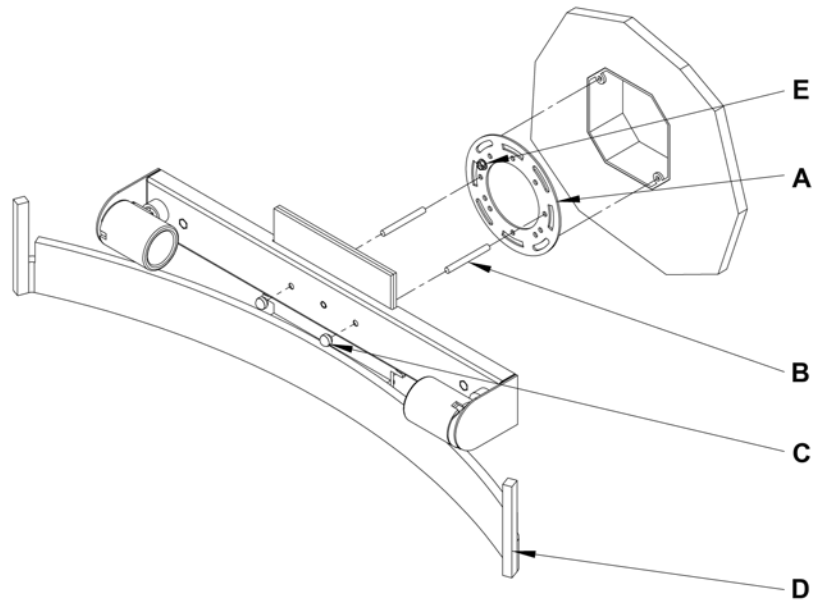

(Figure 1)

(continued)

Installation Instructions

For Sconce 20-6410 & 20-6410F

B211

Page 2 of 2

To Install Diffuser and Glass (Figures 2 & 3)

Component Parts

- D Fixture Assembly
- F Diffuser
- G Glass
- H 8-32 Screw (2)
- I Flat Washer (2)

1. Slip diffuser (F) into location and let rest on fixture assembly (D). Install 8-32 screws (H) and flat washers (I). Tighten until snug. *Be careful not to over tighten (Figure 2).*
2. Slip glass (G) into slots on fixture assembly (D) align so glass ends protrude equal amounts (Figure 3).
3. Install light bulb. (Fluorescent supplied with fixture)
4. Restore electricity at main breaker.

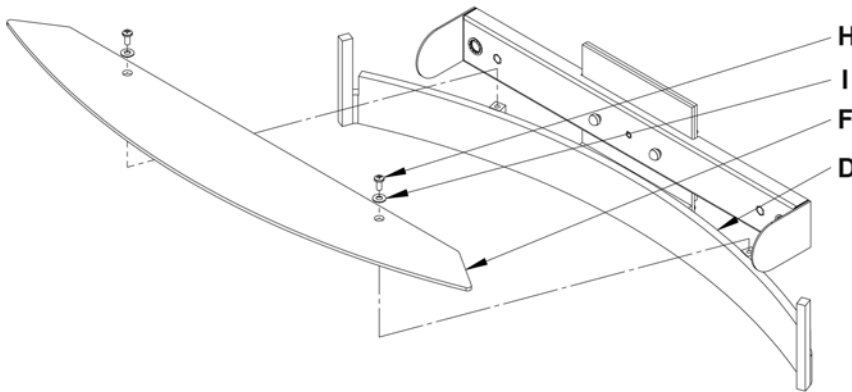

(Figure 2)

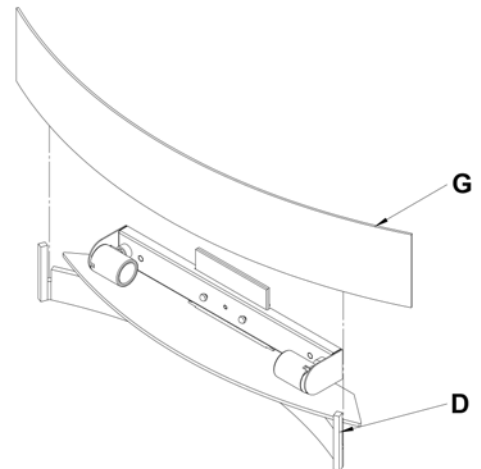

(Figure 3)

If you need further assistance, or find that you are missing any parts please contact the dealer from which you purchased this product. We hope you enjoy your fixture!

* Hubbardton Forge will not be liable for injury or damage caused by improper installation, lamping or use of this fixture.